

PERFORMANCE EVALUATION OF FAULT ON 66 KV SUB-TRANSMISSION LINES

Nay Lin Aung¹, Hlaing Thu², Soe Min Tun³, and Khin Thandar^{4*}

^{*1,3&4}Lecturer, Electrical Power Engineering Department, Pyay Technological University, Myanmar

²Assistant Lecturer, Electrical Power Engineering Department, Pyay Technological University, Myanmar

ABSTRACT

Nowadays, the demand of electricity is increasing day by day and no one needs to get the electricity interruption. Thus, more power must transmit and distribute from one place to the other place without a break. During the power transmission and distribution, some faults are occurred in the system such as unbalanced and balanced faults. These faults affect the power system equipment which is connected to it. The main aim of this research is to analyse the various types of fault and also identifies the fault current in the line because the investigation of power systems under fault condition is one of the most important and complex task in power engineering. Oke Shit Pin sub transmission substation is located in Padaung Township in Myanmar that is chosen for fault analysis studies because different types of faults occur frequently. There are 230 kV incoming line and six 66 kV subtransmission outgoing lines. Matlab program simulation and hand calculation is applied for solving fault problems on 66 kV buses. Comparison of simulation results on various faults with respect to buses are revealed in this journal. By exploring the resulted data, suitable ratings of protective switchgear may be selected.

Keyword: *Fault Analysis, Balanced Fault, Unbalanced Fault, Sub Transmission Line.*

I. INTRODUCTION

An important objective of all the power systems is to maintain a very high level of continuity of service, and when abnormal conditions occur, to minimize the outage times. It is practically impossible to avoid consequences of natural events, physical accidents, equipment failure which results in the loss of power, voltage dips on the power system. Faults are defined as the flow of a massive current through an improper path which could cause enormous equipment damage which will lead to interruption of power, personal injury, or death. Faults on power systems can be divided into three phase balanced faults and unbalanced faults. Three types of unbalanced fault occurrence on power system transmission lines are single line to ground faults, line to line faults, and double line to ground faults. Natural events can cause short circuits i.e. faults which can either be single phase to ground or phase to phase or phase to phase to ground or a three phase fault. In addition, other types of faults rarely occur in the system are open conductor fault and simultaneous fault. Most faults in an electrical system occur with a network of overhead lines are single phase to ground faults caused due to lightning induced transient high voltage and from falling trees. In the overhead lines, tree contact caused by wind is a major cause for faults. This journal is focusing on the analysis of various types of faults in subtransmission system of Oke Shit Pin Township. For the fault investigation at Oke Shit Pin subtransmission system, 66 kV network is selected and analyzed. It is also intended to improve protection schemes in present and future power system. The process of evaluating the system voltages and currents under various types of short circuits is called fault analysis which can determine the necessary safety measures and the required protection system. The magnitude of these currents depends on the internal impedance of the generators plus the impedance of the intervening circuit. The magnitude of the fault current must be accurately calculated in order that mechanical and thermal stresses on equipment may be estimated. The aim of the analysis is to improve the power system stability and reliability of the existing sub transmission system of Oke Shit Pin substation. The fault analysis is carried out by using the fault analysis program in Matlab software. The resulting outputs are described by numerical values. It can provide more understanding upon the effects of various types of faults in transmission system. Fault analysis is the process of determining the magnitude of voltages and line currents during the occurrence of fault on various buses. When a fault occurs within the relay protection zone at any transmission line, a signal will trip or open the circuit breaker isolating the faulted line. To complete this action successfully, fault analysis has to be conducted in every location assuming several fault conditions. The goal is to achieve the optimum protection scheme by determining the fault currents and voltages. This journal will conduct a research, analyze the behavior of a system under fault conditions and evaluate different scenarios of faults.

II. METHODOLOGY FOR FAULT ANALYSIS

Any power system can be analyzed by calculating the system voltages and currents under normal and abnormal conditions. Unfortunately, faults could happen due to natural events or accidents where the phase will establish a connection with another phase, the ground or both in some cases. In this research, the shunt type faults, the most common type of fault taking place in the field are analysed. They involve power conductors or conductor to ground or short circuits between conductors. One of the most essential characteristics of shunt faults is the increment the current suffers and decrease in voltage and frequency. Any unbalanced system can be represented by a number of balanced systems equal to the number of its phasors which are called symmetrical components. In three phase system, there are three sets of balanced symmetrical components such as the positive, negative and zero sequence components. Data of the sequence impedances of synchronous machine, transmission lines and transformers is needed for a numerical analysis of a power system under fault conditions. Subtransient reactance of the synchronous machine is usually taken for fault analysis purposes. The impedances of a transmission line for its positive and negative sequence are the same. In practical, all the sequences impedances are assumed to be the same regardless the transformer type. There are various techniques of fault calculating problems. Computer can be applied to perform fault analysis in well-organized, effective, faster and logical means because symmetrical components method includes many matrix operations. Hand calculation is more time consuming than program simulation. Two types of simulations can be employed in Matlab software such as simulink model and program simulation. In this journal, program simulation and hand calculation is applied for fault analysis studies. Matlab was selected as the simulation tool in this research. Program codes concerned with case study are written with the M-files available in Matlab. This script can be edited and modified based on the user's requirements at any stage. The script will perform specific mathematical operations using given data and generate output solutions. The Matlab code used to solve the problem statement in this research starts by adding the system input. These inputs are mainly reactance of the system transformers, branches and generators. This step is to perform the system admittance. After that, the fault analysis calculations were done for the three phase fault, single line to ground fault, line to line fault and double line to ground fault using the pre-defined functions from Hadi Saadat's known codes. Various fault currents of 66 kV subtransmission lines are calculated by using fault analysis program. The program name for balanced fault is symfault.m program. And lgfault.m, llfault. m and dlfault.m program files are names for unbalanced faults. Zbuild.m program is for bus impedance matrix which is the essential matrix for fault analysis. In this journal, calculated results of three phase fault are compared with simulation results. Bus voltage during fault in per unit is taken as $V_i(0) = 1 \angle 0^\circ$. Formulae needed for hand calculation of fault current and voltage at fault bus are:

$$I_k(F) = \frac{V_i(0)}{(Z^1 + Z_f)} \quad (1)$$

$$V_i(F) = V_i(0) - Z_{ik} I_k(F) \quad (2)$$

III. CASE STUDY

The fault analysis is carried out for 66 kV subtransmission network of Oke Shit Pin substation. The existing system consists of six outgoing feeders. Their voltage rating is 66 kV. All conductor types are used ACSR conductor. The system consists of eight buses, one generator bus for the supply of Oke Shit Pin substation and seven branches to distribute power. The rating of power transformer is 100 MVA that is applied for the reduction of voltage level from 230 kV to 66 kV. The single line diagram of case study is seen from Figure 1.

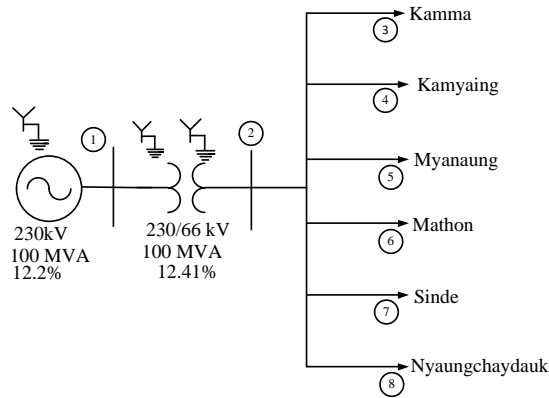

Figure: 1 Single line diagram of Oke Shit Pin substation

The fault currents and voltages are evaluated for all load buses in 66 kV network. Specifications of generator data, transformer data, line data and load data are required variables for performing fault analysis. Load data for 66 kV subtransmission line for Oke Shit Pin substation is shown in Table 1. Among these lines, the maximum loads can be observed at Bus 5 (Myanaung feeder) and its rating is 22.2 MW and line length is 64.374 km.

In Table 2, specifications of positive sequence reactance and negative sequence reactance data of 66 kV outgoing lines are depicted in details. Positive, negative and zero sequence impedance of case study is illustrated in Figure 2 and Figure 3. By using these data, Impedance matrices for positive, negative and zero sequence networks are built in Matlab. For transmission line, positive sequence impedance is equal to negative sequence impedance.

In this section, calculation process and resulted fault currents and bus voltages using the equation (1) and equation (2) for balanced three phase fault are evaluated as the three phase fault is the most severe fault in the power system. And, Bus 7 is chosen as a faulted bus for an example because of the most occurrence fault in the Oke Shit Pin substation. The resulted line currents and bus voltage of three phase fault at Bus 7 are the following.

$$I_7(F) = \frac{V_7(0)}{(Z_{77}^1 + Z_f)} = \frac{1 \angle 0^\circ}{j0.3761 + 0} = 2.6589 \angle -90^\circ \text{ pu}$$

$$V_7(F) = V_7(0) - Z_{77}^1 I_7 = 1 \angle 0^\circ - (j0.3761 \times 2.6589 \angle -90^\circ) = 0 \text{ pu}$$

Line currents for fault at Bus 7 are:

$$I_1(F) = \frac{V_1(0)}{Z_1} = \frac{1 \angle 0^\circ - 0.6756}{j0.122} = 2.5689 \angle -90^\circ \text{ pu}$$

$$I_{12}(F) = \frac{V_1(0) - V_2(0)}{Z_{12}} = \frac{0.6756 - 0.3457}{j0.1241} = 2.5689 \angle -90^\circ \text{ pu} \quad I_{27}(F) = \frac{V_2(0) - V_7(0)}{Z_{27}} = \frac{0.3457 - 0}{j0.13} = 2.5689 \angle -90^\circ \text{ pu}$$

Table 1. Load data 66 kV outgoing lines

Bus No.	Load Consumption	
	P(MW)	Q(MVAR)
3	1.2	-0.98
4	3.1	0.21
5	22.2	8.49
6	1.6	-0.14
7	8.6	3.48
8	3.0	1.25

Table 2. Branch data 66 kV outgoing lines

Bus No. (From)	Bus No. (To)	X ¹ (pu)	X ⁰ (pu)

0	1	0.122	0.122
1	2	0.1241	0.1241
2	3	0.44	1.36
2	4	0.32	0.98
2	5	0.32	0.98
2	6	0.09	0.29
2	7	0.13	0.42
2	8	0.04	0.1

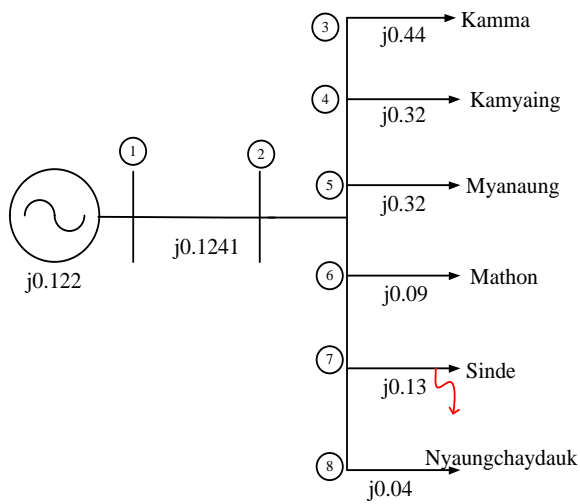

Figure: 2 Positive sequence and negative sequence impedance of Oke Shit Pin substation

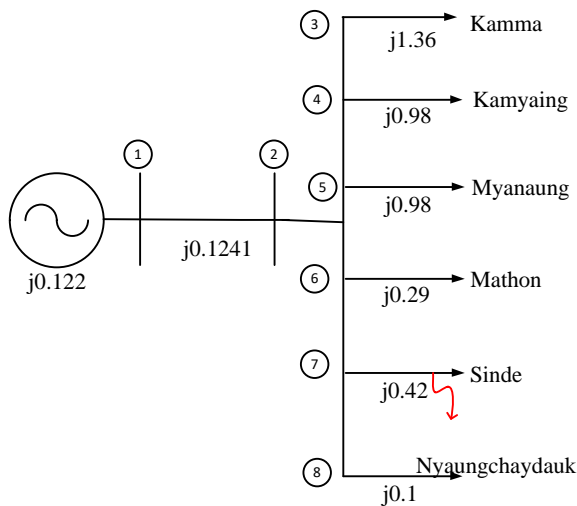

Figure: 3 Zero sequence impedance of Oke Shit Pin substation

$$Z\text{-bus}^1 = Z\text{-bus}^2 =$$

$$\begin{bmatrix} j0.1220 & j0.1220 & j0.1220 & j0.1220 & j0.1220 & j0.1220 & j0.1220 & j0.1220 \\ j0.1220 & j0.2461 & j0.2461 & j0.2461 & j0.2461 & j0.2461 & j0.2461 & j0.2461 \\ j0.1220 & j0.2461 & j0.6861 & j0.2461 & j0.2461 & j0.2461 & j0.2461 & j0.2461 \\ j0.1220 & j0.2461 & j0.2461 & j0.5661 & j0.2461 & j0.2461 & j0.2461 & j0.2461 \\ j0.1220 & j0.2461 & j0.2461 & j0.2461 & j0.5661 & j0.2461 & j0.2461 & j0.2461 \\ j0.1220 & j0.2461 & j0.2461 & j0.2461 & j0.2461 & j0.3361 & j0.2461 & j0.2461 \\ j0.1220 & j0.2461 & j0.2461 & j0.2461 & j0.2461 & j0.2461 & j0.3761 & j0.2461 \\ j0.1220 & j0.2461 & j0.2461 & j0.2461 & j0.2461 & j0.2461 & j0.2461 & j0.2861 \end{bmatrix}$$

Z-bus⁰ =

$$\begin{bmatrix} j0.1220 & j0.1220 & j0.1220 & j0.1220 & j0.1220 & j0.1220 & j0.1220 & j0.1220 \\ j0.1220 & j0.2461 & j0.2461 & j0.2461 & j0.2461 & j0.2461 & j0.2461 & j0.2461 \\ j0.1220 & j0.2461 & j1.6061 & j0.2461 & j0.2461 & j0.2461 & j0.2461 & j0.2461 \\ j0.1220 & j0.2461 & j0.2461 & j1.2261 & j0.2461 & j0.2461 & j0.2461 & j0.2461 \\ j0.1220 & j0.2461 & j0.2461 & j0.2461 & j1.2261 & j0.2461 & j0.2461 & j0.2461 \\ j0.1220 & j0.2461 & j0.2461 & j0.2461 & j0.2461 & j0.5361 & j0.2461 & j0.2461 \\ j0.1220 & j0.2461 & j0.2461 & j0.2461 & j0.2461 & j0.2461 & j0.6661 & j0.2461 \\ j0.1220 & j0.2461 & j0.2461 & j0.2461 & j0.2461 & j0.2461 & j0.2461 & j0.3461 \end{bmatrix}$$

IV. RESULT AND DISCUSSION

In this journal, both the results of hand calculations and output results by Matlab simulation are described with tables and figures. The calculated data of fault currents by using equation (1) and bus voltages by applying equation (2) for three phase fault at Bus 3, Bus 4, Bus 5, Bus 6, Bus 7 and Bus 8 are depicted in the below Table 3 and Table 4. From the two tables, fault currents of Bus 6, Bus 7 and Bus 8 are the highest and bus voltage is reduced to zero at Bus 7.

Table 3. Calculated fault currents of three phase fault at 66 kV Outgoing lines

Bus no.	Fault current of three phase fault	
	Magnitude (pu)	Angle (Degree)
3	1.4575	-90
4	1.7665	-90
5	1.7665	-90
6	2.6753	-90
7	2.6589	-90
8	3.4953	-90

Moreover, fault currents of Bus 3, Bus 4, Bus 5, Bus 6, Bus 7 and Bus 8 at various types of faults are discussed in Table 5 and Figure 3. These data are explained in per unit to evaluate and understand easily. This discussion is done for all types of faults. By analysing the simulated results in Table 5, the values of fault currents for three phase fault are the maximum values among the other fault types.

Table 4. Calculated fault bus voltages of three phase fault at Bus 7

Bus no.	Bus voltage of three phase fault	
	Magnitude (pu)	Angle (Degree)

3	0.3457	0
4	0.3457	0
5	0.3457	0
6	0.3457	0
7	0.0000	0
8	0.3457	0

Table 5. Resulted fault currents with respect to types of faults for 66 kV outgoing lines

Fault currents at various types of faults				
Bus no.	Three phase (pu)	Line to line (pu)	Single line to ground (pu)	Double line to ground (pu)
3	1.4575	1.2622	1.0073	0.7696
4	1.7665	1.5298	1.2721	0.9939
5	1.7665	1.5298	1.2721	0.9939
6	2.9753	2.5767	2.4828	2.1302
7	2.6589	2.3026	2.1152	1.7561
8	3.4953	3.027	3.2669	3.0665

In this journal, the comparison of fault currents at Bus 3, Bus 4, Bus 5, Bus 6, Bus 7 and Bus 8 for both of faults currents by hand calculation and Matlab simulation for only three phase fault are explained in Figure 4 as a sample because of page limitation. It can be seen that the results from the simulation output almost matches the hand calculation results except Bus 6. Small error is occurred at Bus 6. The error of Bus 6 is 0.3 per unit value. The other values at the rest buses are identical. The accuracy of the hand calculation will be affirmed by comparing its results with the output of Matlab simulation.

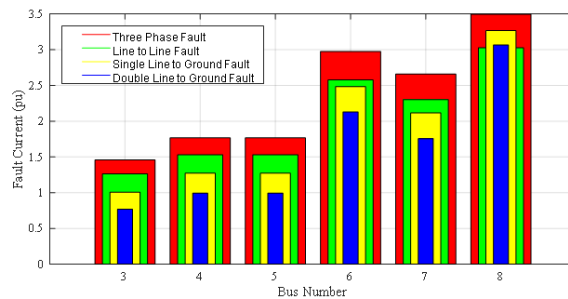

Figure: 3 Comparison results of various faults at six buses

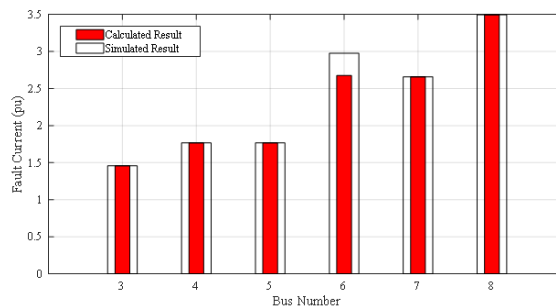

Figure: 4 Comparison of calculated and simulated results for three phase fault

V. CONCLUSION

In Oke Shit Pin substation, the fault currents at all 66 kV bus are calculated for three phase fault by hand calculation and Matlab simulation. As seen from the above tables and figures, the bus voltage at faulted bus dropped to zero during the fault in three phase fault. This type of fault is the most severe fault in the system. During the occurrence of line to line fault, the voltages at both phases are equal. This type is the second severe fault on the case study. And, single line to ground fault current is the third highest fault currents of all types. In addition, this type of fault is the least fault in the system which can be seen from its current value in double line to ground fault. After examining the value of fault current, appropriate relay setting for the protection system and suitable circuit breakers are easy to choose and installed. By doing the research of fault analysis studies, the required ratings of the protective switchgear are also used to obtain for the case study.

VI. ACKNOWLEDGEMENTS

First of all, the authors are deeply grateful to Dr. Nyunt Soe, Rector of the Pyay Technological University, for his kind permission to submit this research work. The authors are much obliged Dr. Soe Winn, Professor and Head of the Department of Electrical Power Engineering of the Pyay Technological University, for his invaluable advice, support and encouragement throughout this research. The authors are greatly indebted to their colleagues at Department of Electrical Power Engineering of the Pyay Technological University, for their helpful suggestions and cooperation. The authors would also like to extend their appreciation to the Assistant Engineer of 230/66 kV Oke Shit Pin substation, for his useful clarification and good willingness to share ideas.

REFERENCES

1. J. Glover and M. Sarma, "Power System Analysis and design", PWS Publishers, Boston, 1987.
2. J. Grainger and W. Stevenson, "Power System Analysis", McGraw-Hill, 1994.
3. Hadi Saadat, "Power System Analysis", International Editions, McGraw-Hill Book Companies, Singapore, 1999.
4. J. C. Das, "Power System Analysis: Short-Circuit Load Flow and Harmonics", 2002.
5. J R Lucas, "Power System Analysis: Faults", 2005.
6. Jorge Santamaria, "Analysis of Power Systems under Fault Conditions", 2006.
7. Holly Moore, "MATLAB for Engineers", 3rd Edition, ISBN-13: 978-0-13-210325-1 ISBN-10: 0-13-210325-7, 2012.
8. Oke Shit Pin Substation, "A Department Report", Padaung Township, Pyay City, Myanmar, 2018.