

## ADVANCEMENTS IN FOOTSOLE PRESSURE DISTRIBUTION SENSING FOR MOBILITY ASSESSMENT

Grace Thompson<sup>1</sup>, William Thompson<sup>1</sup>, Mia Walker<sup>2</sup>

<sup>1</sup> Department of Sociology, University of Edinburgh, UK

<sup>2</sup> Department of Earth Sciences, University of Cape Town, South Africa

---

### ABSTRACT

The final design of the “Smart Shoe” can be broken down into two main components: the data collection and processing system, and the control of the shoes variable stiffness. The force distribution of a user’s foot will be measured using force-sensing resistor (FSR) sensors, while a Arduino Mega and a custom printed circuit board (PCB) collect and process the force data. Ten FSR sensors are distributed along the insole and communicate with a MATLAB program via Bluetooth. When certain force thresholds are exceeded, the software attempts to vary the stiffness of the insole in order to adjust the forces to an acceptable level. The software does this by triggering solenoid valves and an air compressor to control air-flow inside the shoe that will modify its stiffness. An HC-05 chip is used to transfer the sensor readings via Bluetooth to the MATLAB program. This project it’s intense application in the field of the medicine. Not only it is portable but it is also very convenient device. Further this inexpensive device makes it Approximately 42% of females and 31% of males over 60 years old have some form of knee arthritis. This manifests as sharp pains in the knee upon moving and is ranked as one of the top 5 leading causes of disability among non-institutionalized adults. The recommended treatment options for this condition include surgery, cortisone injections, and foot orthotics. Foot orthotics usually consist of a “custom fit” insole designed to place the foot in an ideal position for running or walking. While effective, high variations between different orthotics could necessitate multiple orthotics per patient. Arthritis continues to contribute \$28.5 billion and \$13.7 billion in knee and hip joint replacements respectively per year.

*Keywords: Flex Sensor, Medical Devices, Potentiometer, LCD, Foot orthotics etc.*

---

### I. INTRODUCTION

In the United States, approximately 37% of all adults 60 year or older suffer from kneeosteoarthritis. Custom fit orthotics, while helpful, fail to completely alleviate pain caused by this illness. A major weakness of these orthotics is their inability to adapt to changing conditions, either in the patient or the ground. The Smart Shoe solves this issue with the following features:

Adjustable fit to adapt to changing conditions. Pressure sensors to collect foot strike pattern. Algorithm for foot strike analysis and suggestion. Pneumatic control for stiffness variation. The Combination of the Sole with the flex sensor connected to the LCD panel makes it very crucial in the analysis and simple in the procedure.

### II. OBJECTIVE

To develop a device for analyse pressures distribution at foot sole.

### III. MATERIAL AND METHODOLOGY

#### *Algorithm*

**Step 1:** Turn the device on.

**Step 2:** Step on the sole.

**Step 3:** Take different pressures of the feet.

**Step 4:** Analyse those readings.

#### *Our Proposed System*

Our project is based on instrumentation in medical field. Also, cost has been kept 'under control so that the use of this project can reach masses. The hardware and software are the two important areas in our project.

## Hardware Description

In this project, we have used Atmel AT89C52 processor. Flex sensor have been used to obtain the pressures at different areas precisely. Potentiometer are used for comparing the values and the values are then send to the LCD for displaying the values. Hardware has been designed very efficiently keeping the portability factor in the mind .

## Software Description

Embedded C has been used by and large for programming the Atmel microcontroller. Effective and efficient code has been chalked out so that there is minimal latency rate. Also any bug can't crawl into the system the checks have been provided in the code.

## IV. PROTOTYPE DESIGN

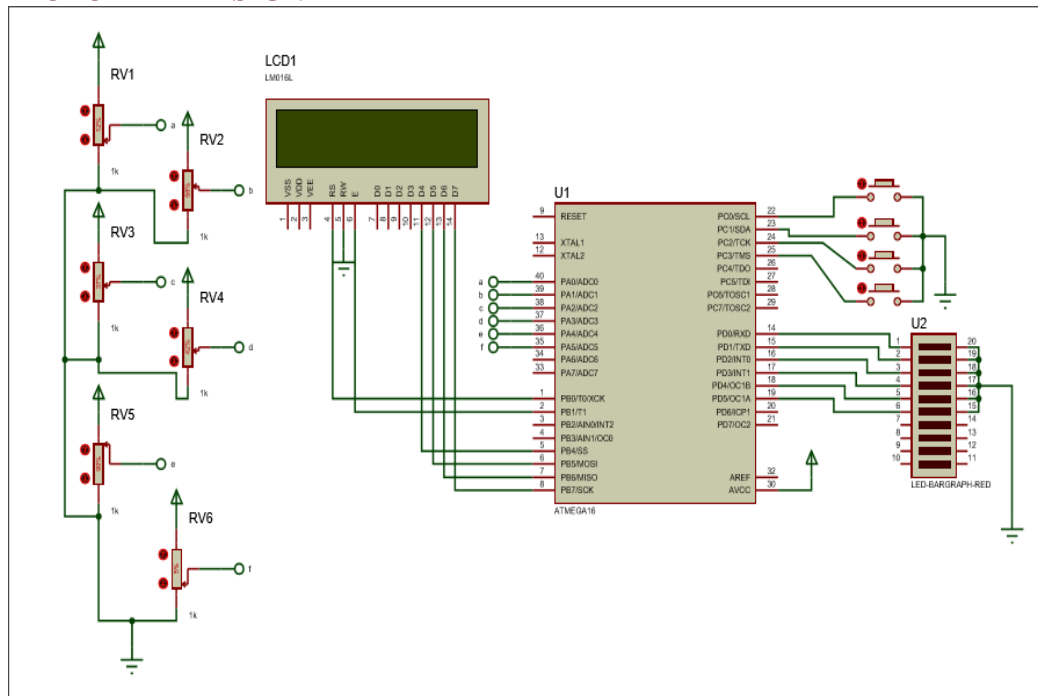

Fig. 3 Connection Diagram

The above image shows the interfacing of the various inputs and outputs connected in our project. The Atmel processor requires 5 V which is supplied through a battery. Flex sensors deployed at various regions of the sole. The data collected from the flex sensors are then sent to the LCD panel. The collected data is further analysed and successive conclusion is drawn.

## V. LIMITATIONS

The only limitation of this system is that it has 6 flex sensors installed on the system. Further installation of more sensors can help boost the analysis.

Also, this system is not so robust as demanded by the industries.

## VI. FUTURE WORK

There are many avenues of improvement after the development of this project. For example, a decrease in the size of the design would benefit users of all shoe sizes. The smaller the mechanisms are, the more versatile it can be. Additionally, one can expect a constantly changing algorithm. Rolling out adaptable algorithms that can be catered to the movements and lifestyle of the user would help tremendously. Lastly, if a phone application can be developed, it would be able to sync with the force data gathered through the shoe. A visualization of this data would be helpful to the user, physician, and other stakeholders to better suggest areas of improvements to the user.

## VII. CONCLUSION

This project endeavours very useful purpose in the medical field . The system is developed for present needs. The purpose of high security threats and managing people with better security at all possible place the proposed system is useful. According to present needs circuit is implemented with reliability. Implementation of system is easy and it is to fabricate with low cost. The detection of pressure is done by developing an embedded system. Feet provide the primary surface of interaction with the environment during locomotion.

Thus, it is important to diagnose foot problems at an early stage for injury prevention, risk management and general wellbeing. One approach to measuring foot health, widely used in various applications, is examining foot plantar pressure characteristics. It is, therefore, important that accurate and reliable foot plantar pressure measurement systems are developed. One of the earliest applications of plantar pressure was the evaluation of footwear. The development of miniature, lightweight, and energy efficient circuit solutions for healthcare sensor applications is an increasingly important research focus given the rapid technological advances in healthcare monitoring equipment, microfabrication processes and wireless communication. One area that has attracted considerable attention by researchers in biomedical and sport related applications is the analysis of foot plantar pressure distributions to reveal the interface pressure between the foot plantar surface and the shoe sole.

## REFERENCES

1. Williams, B. W. (1992). Chapter 11. "Power electronics : devices, drivers and applications ". Basingstoke: Macmillan. ISBN 978-0-333-57351-8.
2. Arrillaga, Jos; Liu, Yonghe H; Watson, Neville R; "Self-Commutating Converters for High Power Applications". John Wiley & Sons. ISBN 978-0-470-68212-8.
3. Castellano, Joseph A (2005). "Liquid Gold: The Story of Liquid Crystal Displays and the Creation of an Industry". World Scientific Publishing. ISBN 978-981-238-956-5.
4. Kenneth L. Kaiser (2004). "Electromagnetic Compatibility Handbook" CRC Press. pp. 13–52. ISBN 978-0-8493-2087-3.
5. Croft, Terrell; Summers, Wilford, eds. (1987). "American Electricians' Handbook" . New York: McGraw Hill. p. 7-124. ISBN 0-07-013932-6.
6. Sinclair, Ian R. (2001), "Sensors and Transducers ", Elsevier, p. 262, ISBN 978-0-7506-4932-2
7. Bird, John (2010). "Electrical and Electronic Principles and Technology". Routledge. pp. 63–76. ISBN 9780080890562.
8. Floyd, Thomas (1984–2005). "Electronic Devices Upper Saddle River", NJ: Pearson Education. p. 10. ISBN 0-13-127827-4.
9. Tooley, Mike (2012). "Electronic Circuits: Fundamentals and Applications", 3rd Ed. Routledge. p. 81. ISBN 1-136-40731-6.
10. Gupta, K. M.; Gupta, Nishu (2015). "Advanced Semiconducting Materials and Devices". Springer. p. 236. ISBN 9783319197586.